

Fitting Instructions

Revo Intake Upgrade Kit 3.0 TFSI B8 S4/S5 (8K/8T)

Fitting Difficulty



Dealer Fit Recommended

Contents

Description	Quantity
Revo Intake Pipe	1
Revo Intake Heatshield	1
Revo Intake Bracket	1
Revo Intake Bracket for CREC Engine	1
Revo Air Filter	1
Revo Coupler Hose	1
Revo Breather Filter	1
Revo Breather Filter Bracket	1
70-90 Hose Clamp	3
M6x16 Hex Bolt	1
M6 Flat Washer	3
M6 Nylock Nut	1
M6x50 Hex Bolt	1
M6x50 Rawl Nut	1
M8x20 Hex Bolt	1
M8 Flat Washer	2
M8 Nylock Nut	1
35 P-Clip	1
90° Hose Connector	1
6mm ID Vacuum Hose	1
Fuel Hose Relocation Kit (both B8 and 8.5)	1

Recommended Tools

Tools	Size
Ratchet	
Extension	
Sockets	7, 10, 13mm
Spanner	10, 13mm
Torx Bits	T25, T30
Flat head Screwdriver	Small



Before starting, please ensure that the battery is disconnected and the engine is cool. Engine temperatures can remain high for a substantial amount of time after use.

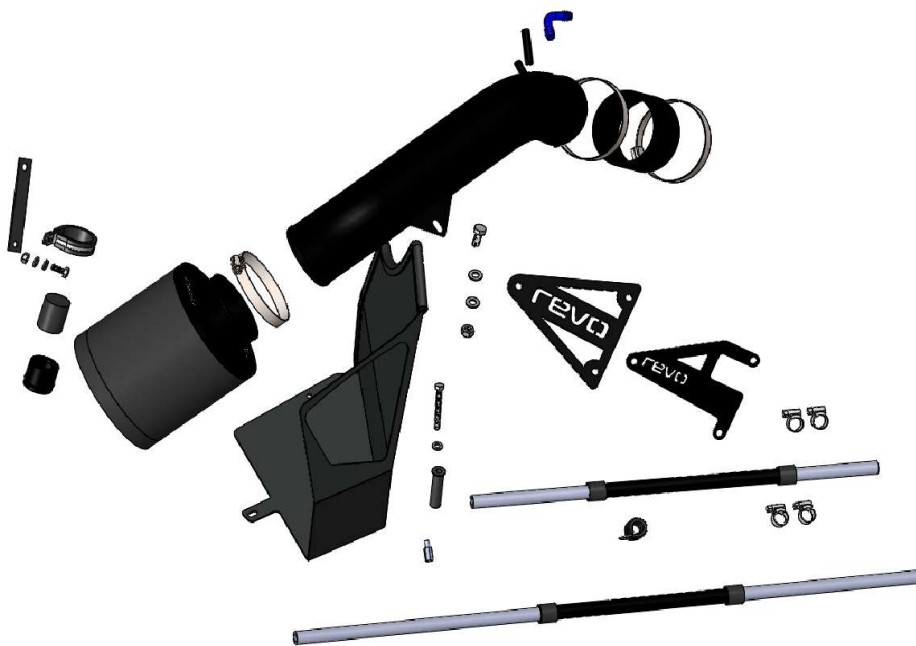

Fitting Instructions

Revo Intake Upgrade Kit 3.0 TFSI B8 S4/S5 (8K/8T)

Fitting Difficulty



Dealer Fit Recommended



Installation was performed on a UK-spec. B8.5 S5 (8T). Installation on other vehicles will be similar but may not be exact.

- 1 Raise the vehicle to gain access to the underside.

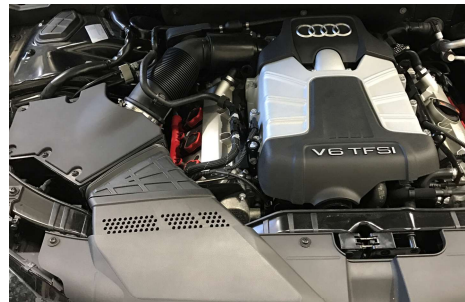

- 2 Using a T30, remove the 4 x bolts along the slam panel and then pull free from the 6 x clips along the front edge.

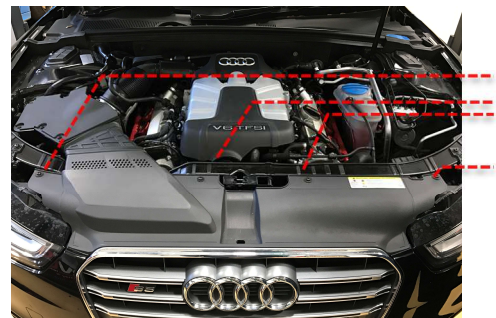

- 3 Remove the 2 x T25 bolts from the front intake and place out of the work area.



- 4 Unclip the intake ducting from the airbox and remove from the vehicle.

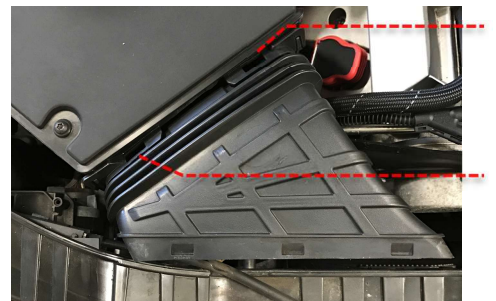

Fitting Instructions

Revo Intake Upgrade Kit 3.0 TFSI B8 S4/S5 (8K/8T)

Fitting Difficulty



Dealer Fit Recommended

- 5 Unclip the rubber hoses from the intake pipe and place out of the work area.

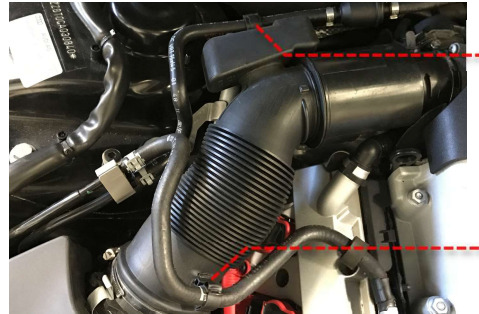

- 6 Using a 7mm socket, loosen the hose clamp on the airbox end of the intake pipe and remove the pipe from the airbox.

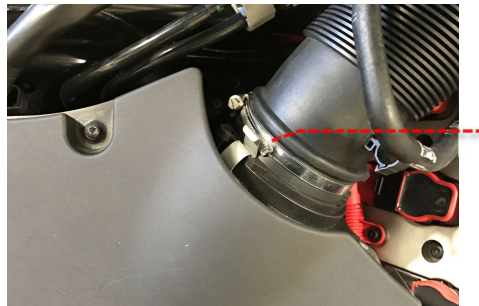

- 7 Remove the airbox from its mounts by pulling firmly upwards. Do not remove completely yet as the breather hose is still connected on the underside.

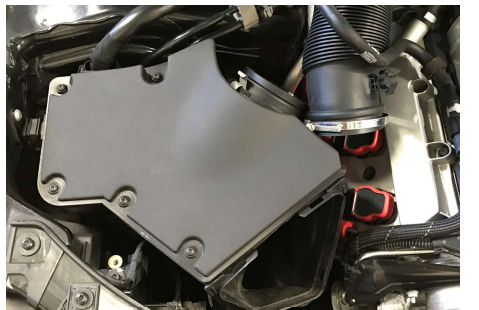

- 8 Disconnect the breather hose by squeezing the tabs and pulling the hose free. The airbox can be removed from the vehicle and placed out of the work area.



Fitting Instructions

Revo Intake Upgrade Kit 3.0 TFSI B8 S4/S5 (8K/8T)

Fitting Difficulty



Dealer Fit Recommended

- 9 Remove the vacuum hose from the back of the intake pipe. Next, use a 7mm socket to loosen the hose clamp and remove the intake pipe from the vehicle.



- 10 At this stage, complete the fuel hose relocation using the "Revo Fuel Line Relocation Kit" fitting instructions available from the Revo website.

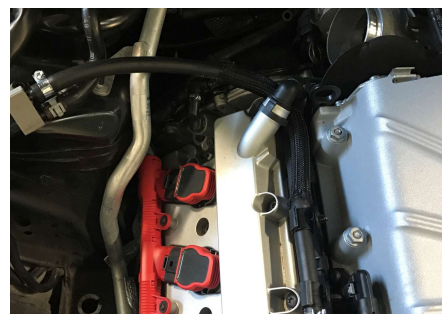

- 11 Take the Revo breather filter (supplied) and press into the breather hose until it clicks into place. Next take the P-clip (supplied) and place around the breather hose. Secure the P-clip to the Revo bracket using a M6 bolt, M6 washer on either side of the P-clip and a M6 nylock nut. Do not tighten fully yet.



- 12 Remove the T25 bolt securing the OE airbox mounting bracket. This bracket can be placed out of the work area.

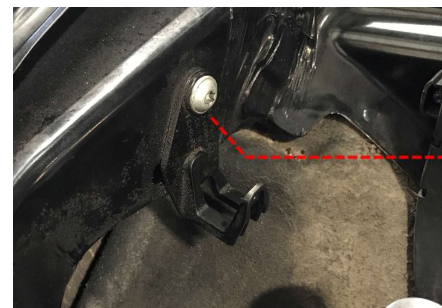

Fitting Instructions

Revo Intake Upgrade Kit 3.0 TFSI B8 S4/S5 (8K/8T)

Fitting Difficulty



Dealer Fit Recommended

- 13 Attach the breather assembly to the inner wing using the bolt removed in step 12 and tighten to OE torque specification. Position the breather filter so that it has sufficient clearance and tighten the M6 bolt using a 10mm socket and 10mm spanner.



- 14 Remove one of the rubber mounts from the bottom of the OE airbox and press in to the rear airbox mounting hole in the chassis leg.



- 15 Remove the T25 bolt from the back of the headlight.

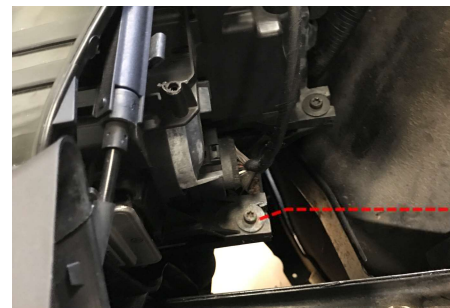

- 16 Take the rawl plug (supplied) and secure to the heatshield using the M6 x 50mm hex bolt.

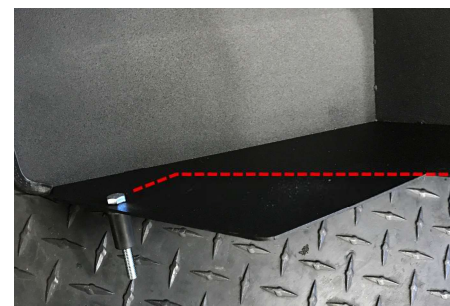

Fitting Instructions

Revo Intake Upgrade Kit 3.0 TFSI B8 S4/S5 (8K/8T)

Fitting Difficulty



Dealer Fit Recommended

- 17 Place the heatshield into the engine bay and press the rawl plug in to the rubber mount from step 14. Next refit the headlight bolt through the heatshield and tighten to OE torque specification.

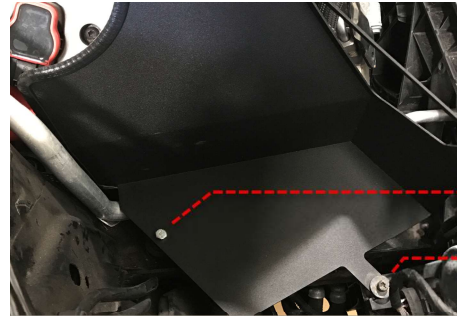

- 18 Refit the front air intake and slam panel.



- 19 Clip the OE intake ducting into the heatshield and into the front air intake.



- 20 Take the Revo intake coupler hose with 2 x 70-90 hose clamps and place onto the throttle body. Position the hose clamps so they can easily be accessed but do not tighten yet.

Note: the plastic throttle body cover can be removed for ease of access.

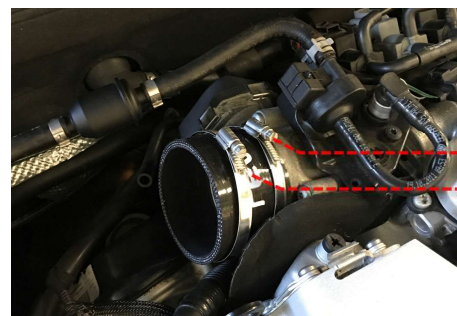

Fitting Instructions

Revo Intake Upgrade Kit 3.0 TFSI B8 S4/S5 (8K/8T)

Fitting Difficulty



Dealer Fit Recommended

- 21 Fit the Revo air filter to the Revo intake pipe with a 70-90 hose clamp as shown. Do not tighten the clamp fully yet. Take the air filter oil (supplied) and apply an even coat to the whole filter.



- 22 Press the filter and intake pipe assembly in to the Revo intake coupler hose and position correctly in the engine bay. Do not tighten the 3 x hose clamps fully yet.

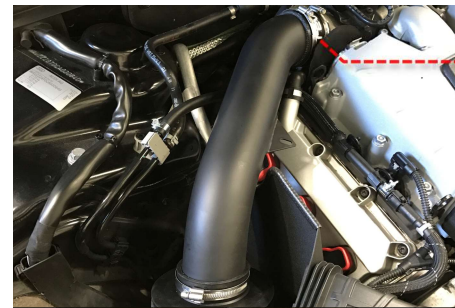

- 23 Using a 13mm socket, remove the 2 x nuts closest to the throttle body securing the supercharger.

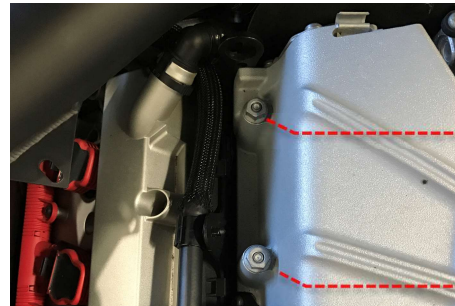

- 24 Take the Revo bracket (supplied) and place over the 2 x supercharger studs. Next, secure the intake pipe to the bracket using the supplied M8 x 20mm bolt, 2 x M8 washers and M8 nylock nut. Refit the 2 x supercharger nuts but do not tighten fully yet.

Note: for CREC engine vehicles use the CREC bracket, which can be seen in the lower photo.

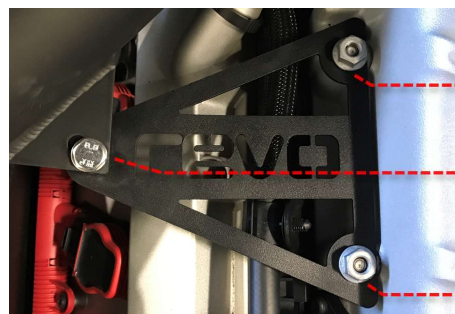

Fitting Instructions

Revo Intake Upgrade Kit 3.0 TFSI B8 S4/S5 (8K/8T)

Fitting Difficulty



Dealer Fit Recommended

- 25 Once all the components of the intake kit are in the correct position, use a 7mm socket to tighten the 2 x 70-90 hose clamps on the throttle body hose and the 70-90 hose clamp on the air filter. Next, use a 13mm socket and a 13mm spanner to tighten the M8 bolt that secures the intake pipe to the bracket. Finally using a 13mm socket, tighten the 2 x nuts on the supercharger to the OE torque specification.

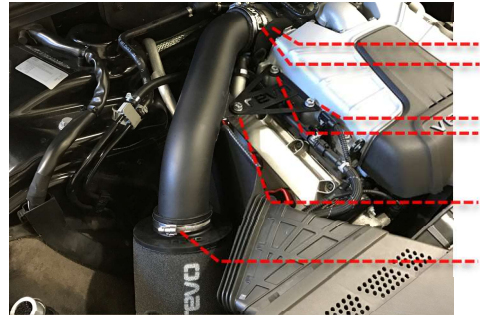

- 26 For CREC engine vehicles take the Revo 90° hose connector and fit to the vacuum pipe near the throttle body. Next, take the 6mm vacuum hose that is supplied with the kit and fit one end to the 90-degree connector and the other end to the take-off on the underside of the intake pipe.

On non CREC vehicles simply reconnect the small take off pipe to the small take off on the back of the pipe.



- 27 Start engine and check for any air leaks or fuel leaks. Refit the plastic covers. Test drive to ensure the vehicle performs correctly and there are no leaks/part interference during operation. Your installation is now complete!

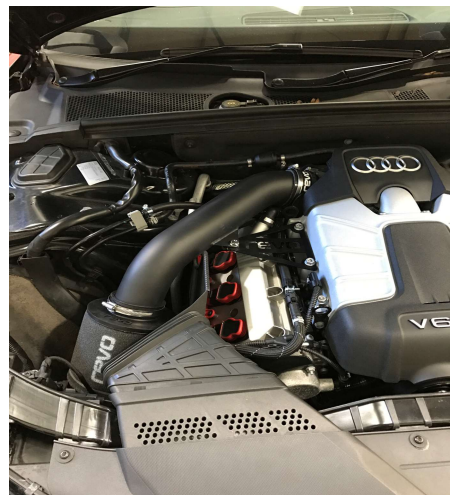

Fitting Instructions

Revo Intake Upgrade Kit 3.0 TFSI B8 S4/S5 (8K/8T)

Fitting Difficulty



Dealer Fit Recommended

NO.	DESCRIPTION	QTY.
1	HEATSHIELD	1
2	INTAKE PIPE ASSEMBLY	1
3	SILICONE JOINER	1
4	AIR FILTER	1
5	88/8 S LOGO BRACKET	1
6	CREC ENGINE LOGO BRACKET	1
7	M8 x 1.25 x 20MM STAINLESS STEEL HHCS	1
8	M8 STAINLESS STEEL FLAT WASHER	2
9	M8 x 1.25 STAINLESS STEEL NYLOCK NUT	1
10	BREATHER FILTER BRACKET	1
11	BREATHER CONNECTOR	1
12	37MM I/D VINYL-LINED STAINLESS STEEL P-CUP	1
13	M6 x 1.0 x 50MM RUBBER STANDOFF	1
14	M6 STAINLESS STEEL FLAT WASHER	3
15	M6 x 1.0 x 50MM STAINLESS STEEL HHCS	1
16	M6 x 1.0 x 14MM STAINLESS STEEL HHCS	1
17	M6 x 1.0 STAINLESS STEEL NYLOCK NUT	1
18	B8 FUEL HOSE RELOCATION KIT	1
19	B8 S/CREC FUEL HOSE RELOCATION KIT	1
20	70-90MM HOSE CLAMP S/S	3
21	BREATHER FILTER	1
22	90 DEGREE HOSE CONNECTOR 4MM I/D	1
23	40MM LENGTH 4MM I/D VACUUM HOSE	1

